

ITEM NO.	PART NUMBER	PROCESS	MATERIAL	FINISH	QTY.
1	SCH_~250-20 UNC_0~75_SIMP	stock item	stainless steel	raw	6
2	RWA-310707-P1-REV-PO-(SI Team Waterski Rack)	machined	6061 Alloy	polished	1
3	RWA-120906-G1-REV-G0-(Stainless Steel Board Rack Clip)	cut and fold	stainless steel	polished	1
4	COB-201205-G7-REV-G0-(Custom Locking Pin)	stock item	stainless steel	raw	2
5	SSCR-HEX-CP_~190-24 UNC_0~375_HELI	stock item	stainless steel	raw	2
6	RWA-160106-G1-REV-G1-(Roswell Medalion)	Die Cast	6061 Alloy	Chrome plated	1
8	RWA-060707-P5-REV-PO-(Tine and Rubber Ski Rack Assembly)	see sub assembly	see sub assembly	see sub assembly	2
9	Waterski Rack Strap Assembly (Not shown- will connect to backing plate & clip)	cut and sew	bungee core and webbing	black - UV stable	1

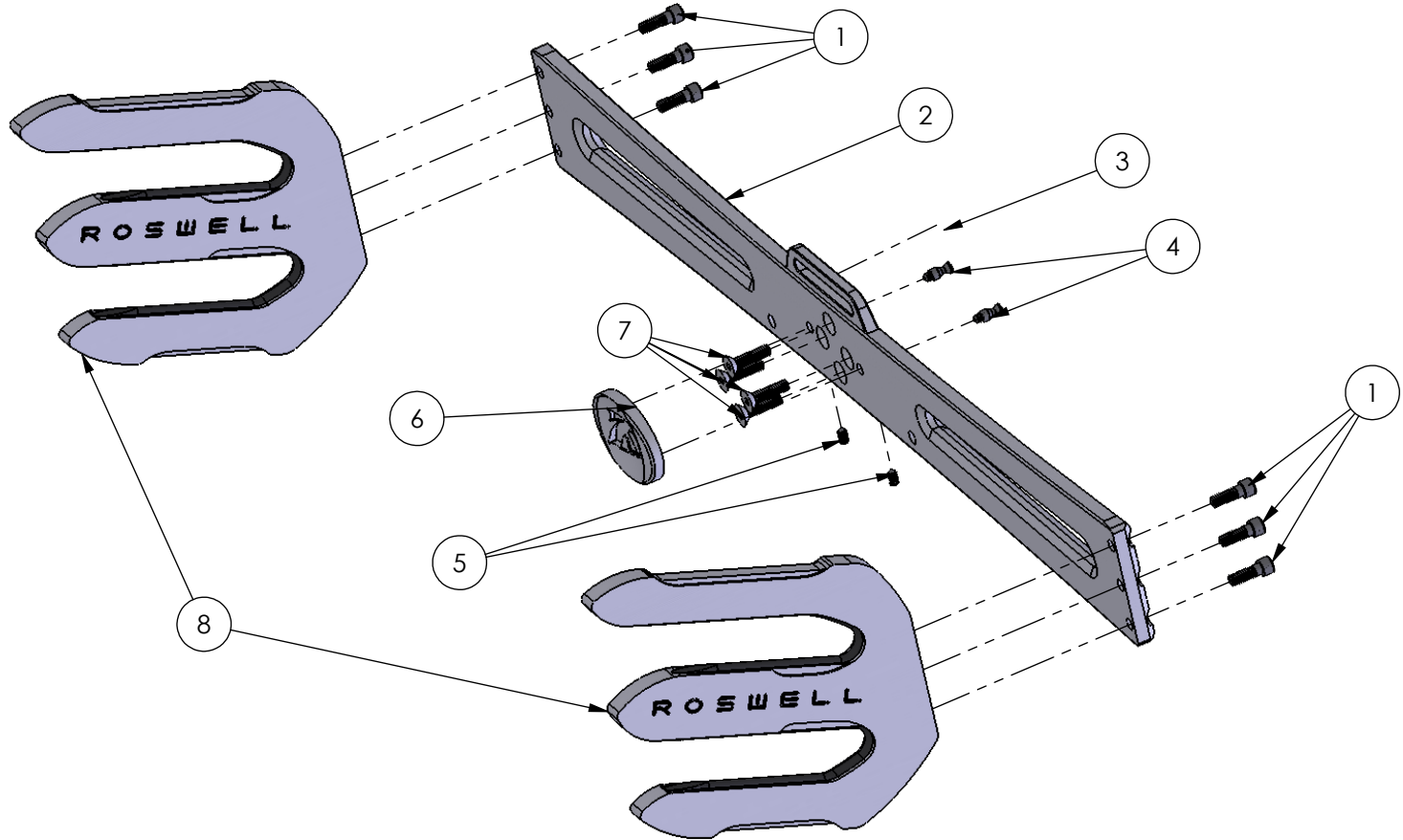

REVISION NOTES:

UNLESS OTHERWISE SPECIFIED:

DIMENSIONS ARE IN INCHES

TOLERANCES:

DECIMAL: x. ± 0.06
x.x ± 0.03
x.xx ± 0.015
x.xxx ± 0.005
FRACTIONAL: xx x/x ± 1/16"
x x/x ± 1/32"
x/x ± 1/64"
ANGULAR: ±0.5°



RWA-310707-P2-REV-PO-(Complete Waterski Rack Assembly)

BRAND-DATE-DESIGNER-REVISION-(Description)

SCALE: 1:1 REVISION DATE: Monday, December 10, 2007

PROPRIETARY AND CONFIDENTIAL
THE INFORMATION CONTAINED IN THIS DRAWING IS THE SOLE PROPERTY OF ROSWELL WAKE AIR. ANY REPRODUCTION IN PART OR AS A WHOLE WITHOUT THE WRITTEN PERMISSION OF ROSWELL WAKE AIR IS PROHIBITED.

DRAWN BY: egagnon MATERIAL: SEE BOM TABLE
PROCESS: SEE BOM TABLE FINISH: SEE BOM TABLE

DO NOT SCALE DRAWING

5

4

3

2

1